



产品不断更新, 样本如有变动恕不另行通知
Constantly updated products, samples are subject to change without prior notice

诚信 · 专业 · 品质 · 服务
Integrity · Speciality · Quality · Serve

无锡艾克顿流体科技有限公司



地址: 无锡市新吴区城南路32-5
TEL: 153 3520 5123 余经理
Http: www.wxaccton.com
E-mail: Accton01@Accton.com
Accton02@Accton.com



气动执行器

PNEUMATIC ACTUATORS

无锡艾克顿流体科技有限公司

Stainless Steel Actuator

A 系列不锈钢执行器

- 316L、316、304、303不锈钢材质执行器，外表电解抛光，光洁美观，抗腐蚀性能强，适合于抗腐蚀要求极高的工程环境。
- 双活塞齿轮齿条式设计，结构紧凑、安装位置对称、改变输出轴转向方便，使用寿命长、动作迅速。
- 活塞齿条背面装有复合轴承及导向环，动作精确、摩擦系数小、使用寿命延长。
- 组合式预负荷镀层弹簧，工作寿命长、抗腐蚀性能强。
- 高精度齿轮和齿条，啮合间隙小、精度高，输出功率大。
- 不锈钢紧固件，安全美观，抗腐蚀性强。
- 采用国际规范尺寸：
输出轴槽、螺孔；顶部安装孔尺寸符合NAMUR标准；
气源接口尺寸符合NAMUR标准；
底部安装孔尺寸符合ISO5211、DIN3337标准，方便安装电磁阀限位开关等附件。

- ASTM316L, 316, 304, 303 stainless steel pneumatic actuator with electro-polish finish offer excellent resistance to most corrosive chemicals as well as industrial atmospheres.
- Dual piston rack and pinion design for compact construction, symmetric mounting position, high-cycle life and fast operation, reverse rotation can be accomplished in the field by simply inverting the pistons.
- Multiple bearings and guides on racks and pistons, low friction, high cycle life and prevent shaft blowout.
- Modular preloaded spring cartridge design, with coated spring for simple versatile range, greater safety and corrosion resistance, longer cycle life.
- Fully machined teeth on piston and pinion for accurate low backlash rack and pinion engagement, maximum efficiency.
- Stainless steel fasteners for long term corrosion resistance.
- Full conformance to the latest specifications: ISO5211, DIN 3337 and Namur or product interchangeability and easy mounting of solenoids, limit switches and other accessories.



工作原理 Operating Principle

双作用执行器 Double Acting Actuators

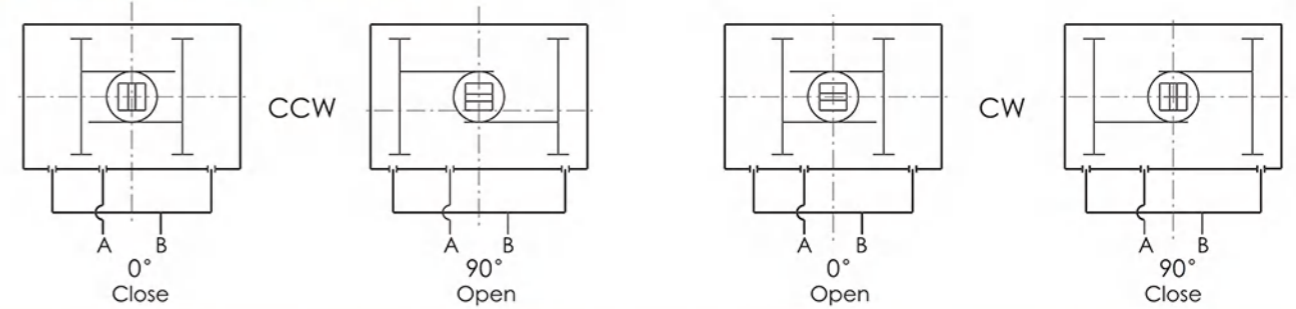

A口进气，压缩空气推动活塞向外运动，使执行器输出轴逆时针旋转(0°→90°)，B口排气。
B口进气，压缩空气推动活塞向内运动，使执行器输出轴顺时针旋转(90°→0°)，A口排气。

Air to Port A forces the pistons outwards, causing the pinion to turn counterclockwise while the air is being exhausted from Port B.
Air to Port B forces the pistons inwards, causing the pinion to turn clockwise while the air is being exhausted from Port A.

A口进气，压缩空气推动活塞向外运动，使执行器输出轴顺时针旋转(90°→0°)，B口排气。
B口进气，压缩空气推动活塞向内运动，使执行器输出轴逆时针旋转(0°→90°)，A口排气。

Air to Port A forces the pistons outwards, causing the pinion to turn clockwise while the air is being exhausted from Port B.
Air to Port B forces the pistons inwards, causing the pinion to turn counterclockwise while the air is being exhausted from Port A.

单作用执行器 Spring Return Actuators

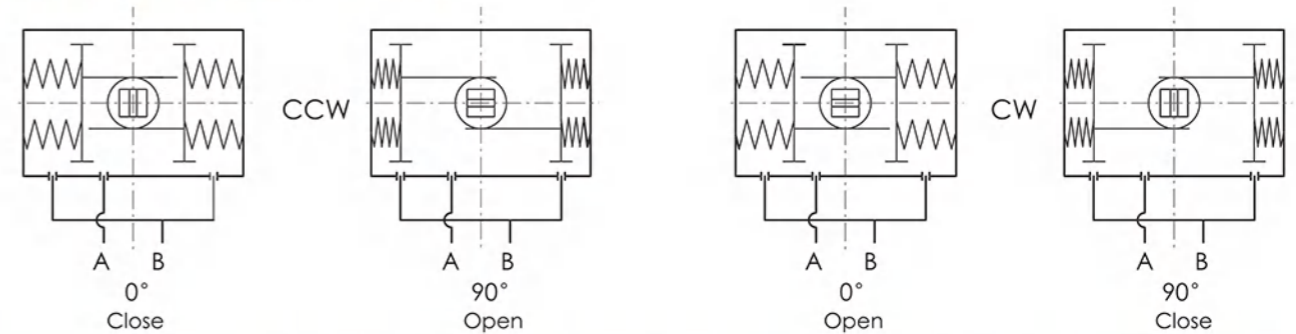

A口进气,压缩空气克服弹簧力,推动活塞向外运动,执行器输出轴逆时针转动(0°→90°), B口排气;
执行器失气,活塞在弹簧力的作用下向内运动,执行器输出轴顺时针转动(90°→0°), A口排气。

Air to port A forces the pistons outwards, causing the springs to compress. The pinion turns counterclockwise while air is being exhausted from port B.
Loss of air pressure on port A, the stored energy in the springs forces the pistons inwards. The pinion turns clockwise while air is being exhausted from port A.

A口进气,压缩空气克服弹簧力,推动活塞向外运动,执行器输出轴顺时针转动(90°→0°), B口排气;
执行器失气,活塞在弹簧力的作用下向内运动,执行器输出轴逆时针转动(0°→90°), A口排气。

Air to port B forces the pistons outwards, causing the springs to compress. The pinion turns counterclockwise while air is being exhausted from port B.
Loss of air pressure on port A, the stored energy in the springs forces the pistons inwards. The pinion turns clockwise while air is being exhausted from port A.

零件和材料 Parts and Materials

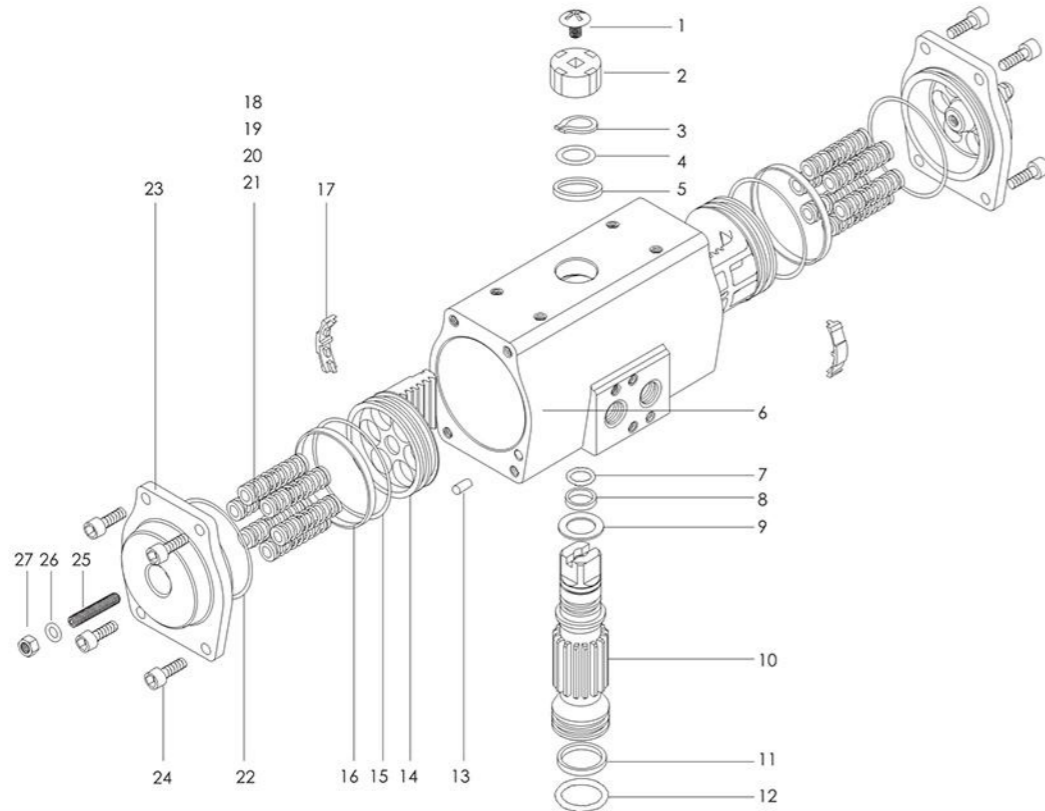

序号 No.	名称 Description	数量 Qty.	材料 Standards Material
1	指示器螺钉 Indicator screw	1	塑料 Plastic(ABS)
2	指示器 Indicator	1	塑料 Plastic(ABS)
3	弹性挡圈 Circlip	1	不锈钢 Stainless steel(304)
4	垫片 Thrust washer	1	不锈钢 Stainless steel(304)
5	外垫片 Outside washer	1	工程塑料 Polyoxymethylene
6	缸体 Body	1	不锈钢 Stainless steel(304)
7	上轴"O"型圈 O-ring(Pinion top)	1	氟橡胶、丁腈橡胶 Viton/NBR
8	上轴支承圈 Bearing(Pinion top)	1	工程塑料 Polyoxymethylene
9	内垫片 Inside washer	1	工程塑料 Polyoxymethylene
10	轴 Pinion	1	不锈钢 Stainless steel(304)
11	下轴支承圈 Bearing(Pinion bottom)	1	工程塑料 Polyoxymethylene
12	下轴"O"型圈 O-ring(Pinion bottom)	1	氟橡胶、丁腈橡胶 Viton/NBR
13	塞头 Plug	2	橡胶 NBR
14	活塞 Piston	2	不锈钢 Stainless steel(304)
15	活塞"O"型圈 O-ring(Piston)	2	氟橡胶、丁腈橡胶 Viton/NBR
16	活塞支承圈 Bearing(Piston)	2	工程塑料 Polyoxymethylene
17	活塞导板 Guide(Piston)	2	尼龙66 Nylon6
18	弹簧 Spring	*	弹簧钢 Spring steel
19	弹簧左套 Spring Retainer(L)	*	尼龙66 Nylon66
20	弹簧右套 Spring Retainer(R)	*	尼龙66 Nylon66
21	弹簧套连杆 Retainer Connector	*	铜 Brass
22	端盖"O"型圈 O-ring(End-Cap)	2	氟橡胶、丁腈橡胶 Viton/NBR
23	端盖 End-Cap	2	不锈钢 Stainless steel(304)
24	端盖紧固螺杆 End-Cap Screw	8	不锈钢 Stainless steel(304)
25	调节螺杆 Adjust Screw	2	不锈钢 Stainless steel(304)
26	调节螺杆"O"型圈 O-ring(Adjust Screw)	2	不锈钢 Stainless steel(304)
27	调节螺杆螺母 Nut(Adjust Screw)	2	氟橡胶、丁腈橡胶 Viton/NBR

双作用扭矩 Output Torque with Double Acting

双作用执行器输出力矩
Output Torque of Double Acting Actuators

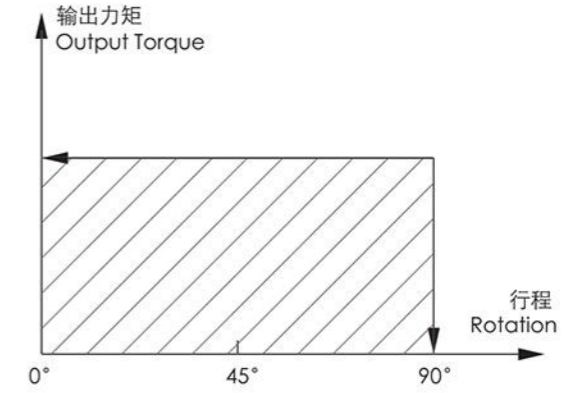

A 系列气动执行器双作用输出扭矩表

Output Torque Table of A Series Pneumatic Actuators with Double Acting

Unit: Nm

规格 Model	气源压力 (巴) Air pressure(Bar)									
	2	2.5	3	4	4.5	5	5.5	6	7	8
A-45DA	6.0	7.6	9.1	12.1	13.6	15.1	16.6	18.1	21.1	24.2
A-60DA	14.2	17.8	21.3	28.4	32.0	35.5	39.1	42.6	49.7	56.8
A-85DA	30.8	38.5	46.2	61.6	69.4	77.1	84.8	92.5	107.9	123.3
A-105DA	65.8	82.2	98.7	131.6	148.0	164.4	180.9	197.3	230.2	263.1
A-125DA	103	128	154	205	231	256	282	308	359	410
A-140DA	175	219	263	351	395	439	482	526	614	702
A-160DA	267	334	401	535	601	668	735	802	935	1069
A-210DA	526	658	789	1052	1184	1316	1447	1579	1842	2105

单作用扭矩 Output Torque with Spring Return

单作用气动执行器输出扭矩

Output Torque of Pneumatic Actuator with Spring Return

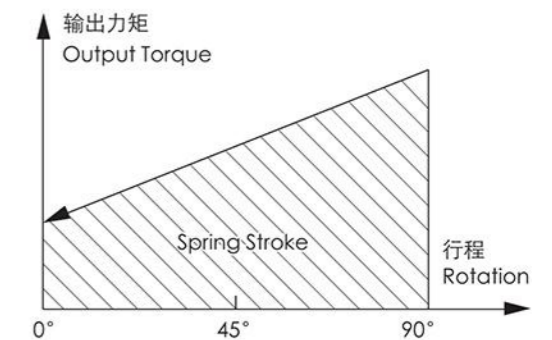
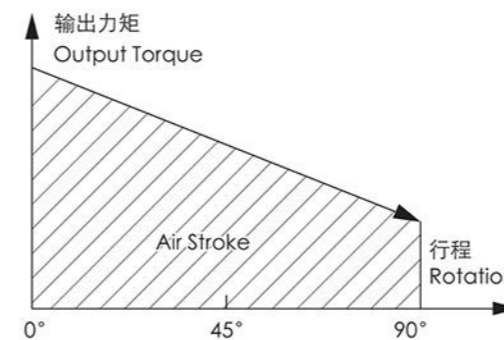

A系列单作用气动执行器输出扭矩表
Output Torque of A Series Pneumatic Actuator with Spring Return

Unit: Nm

规格 (Model)	弹簧根数 Spring Qty.	气源压力(巴) Air pressure(Bar)																弹簧输出扭矩 Springs output		
		2		2.5		3		4		5		6		7		8		90°	0°	
		90° Start	90° End	0° Start	0° End	90° Start	90° End	0° Start	0° End	90° Start	90° End	0° Start	0° End	90° Start	90° End	0° Start	0° End	Start	End	
A-45SR	K5	3.0	1.2	4.6	2.8													4.6	2.9	
	K6	2.3	0.2	3.9	1.8	5.4	3.3											5.5	3.5	
	K7			3.3	0.8	4.8	2.3	7.8	5.3									6.5	4.1	
	K8					4.2	1.3	7.2	4.3	10.2	7.3							7.4	4.6	
	K9							6.6	3.4	9.6	6.4	12.6	9.4					8.3	5.2	
	K10							6.0	2.4	9.0	5.4	12.0	8.4	15.0	11.4	18.1	14.5	9.2	5.8	
	K11									8.4	4.4	11.4	7.4	14.4	10.4	17.5	13.5	10.1	6.4	
	K12									7.8	3.5	10.8	6.5	13.8	9.5	16.9	12.6	11.1	7.0	
	A-60SR	K5	7.0	3.2	10.6	6.8													10.4	6.8
		K6	5.6	1.0	9.2	4.6	12.7	8.1											12.5	8.2
		K7			7.7	2.4	11.2	5.9	18.3	13.0									14.6	9.6
		K8					9.8	3.7	16.9	10.8	24.0	17.9							16.7	10.9
K9								15.4	8.6	22.5	15.7	29.6	22.8					18.8	12.3	
K10								14.0	6.4	21.1	13.5	28.2	20.6	35.3	27.7	42.4	34.8	20.9	13.7	
K11										19.7	11.3	26.8	18.4	33.9	25.5	41.0	32.6	22.9	15.0	
K12										18.2	9.1	25.3	16.2	32.4	23.3	39.5	30.4	25.0	16.4	
A-85SR		K5	14.2	6.6	21.9	14.3													23.0	15.8
		K6	10.8	1.7	18.5	9.4	26.2	17.1											27.6	19.0
		K7			15.2	4.6	22.9	12.3	38.3	27.7									32.2	22.1
		K8					19.6	7.4	35.0	22.8	50.5	38.3							36.8	25.3
	K9							31.6	18.0	47.1	33.5	62.5	48.9					41.4	28.5	
	K10							28.3	13.2	43.8	28.7	59.2	44.1	74.6	59.5	90.0	74.9	46.0	31.6	
	K11									40.5	23.8	55.9	39.2	71.3	54.6	86.7	70.0	50.6	34.8	
	K12									37.1	19.0	52.5	34.4	67.9	49.8	83.3	65.2	55.2	38.0	
	A-105SR	K5	32.5	14.0	48.9	30.4													49.2	31.6
		K6	25.8	3.6	42.2	20.0	58.7	36.5											59.1	38.0
		K7			35.6	9.7	52.1	26.2	85.0	59.1									68.9	44.3
		K8					45.4	15.8	78.3	48.7	111.1	81.5							78.7	50.6
K9								71.7	38.4	104.5	71.2	137.4	104.1					88.6	56.9	
K10								65.0	28.0	97.8	60.8	130.7	93.7	163.6	126.6	196.5	159.5	98.4	63.3	
K11										91.1	50.4	124.0	83.3	156.9	116.2	189.8	149.1	108.3	69.6	
K12										84.5	40.1	117.4	73.0	150.3	105.9	183.2	138.8	118.1	75.9	
A-125SR		K5	47.9	20.5	72.9	45.5													78.4	52.4
		K6	36.9	4.0	61.9	29.0	87.9	55.0											94.1	62.8
		K7			50.8	12.5	76.8	38.5	127.8	89.5									109.7	73.3
		K8					65.8	22.0	116.8	73.0	167.8	124.0							125.4	83.8
	K9							105.8	56.5	156.8	107.5	208.8	159.5					141.1	94.2	
	K10							94.8	40.0	145.8	91.0	197.8	143.0	248.8	194.0	299.8	245.0	156.8	104.7	
	K11									134.8	74.5	186.8	126.5	237.8	177.5	288.8	228.5	172.4	115.2	
	K12									123.7	58.0	175.7	110.0	226.7	161.0	277.7	212.0	188.1	125.7	
	A-140SR	K5	84.7	39.3	128.7	83.3													129.0	85.8
		K6	66.6	12.1	110.6	56.1	154.6	100.1											154.8	102.9
		K7			92.6	29.0	136.6	73.0	224.6	161.0									180.5	120.1
		K8					118.5	45.8	206.5	133.8	294.5	221.8							206.3	137.3
K9								188.5	106.7	276.5	194.7	363.5	281.7					232.1	154.4	
K10								170.4	79.5	258.4	167.5	345.4	254.5	433.4	342.5	521.4	430.5	257.9	171.6	
K11										240.3	140.4	327.3	227.4	415.3	315.4	503.3	403.4	283.7	188.7	
K12										222.3	113.2	309.3	200.2	397.3	288.2	485.3	376.2	309.5	205.9	
A-160SR		K5	120.0	47.7	187.0	114.7													208.3	139.7
		K6	90.6	3.9	157.6	70.9	224.6	137.9											250	168
		K7			128.2	27.0	195.2	94.0	329.2	228.0									292	196
		K8					165.8	50.2	299.8	184.2	432.8	317.2							333	223
	K9							270.4	140.3	403.4	273.3	537.4	407.3					375	251	
	K10							241.0	96.4	374.0	229.5	508.0	363.5	641.0	496.5	775.0	630.5	417	279	
	K11									344.6	185.6	478.6	319.6	611.6	452.6	745.6	586.6	458	307	
	K12									315.2	141.7	449.2	275.7	582.2	408.7	716.2	542.7	500	335	
	A-210SR	K5	237	126	369	258													360	260
		K6	179	46	311	178	442	309											432	313
		K7			253	99	384	230	647	493									503	365
		K8					326	150	589	413	853	677							575	417
K9								531	333	795	597	1058	860					647	469	
K10								473	253	737	517	1000	780	1263	1043	1526	1306	719	521	
K11										679	437	942	700	1205	963	1468	1226	791	573	
K12										621	357	884	620	1147	883	1410	1146	863	625	

外型尺寸 Dimension

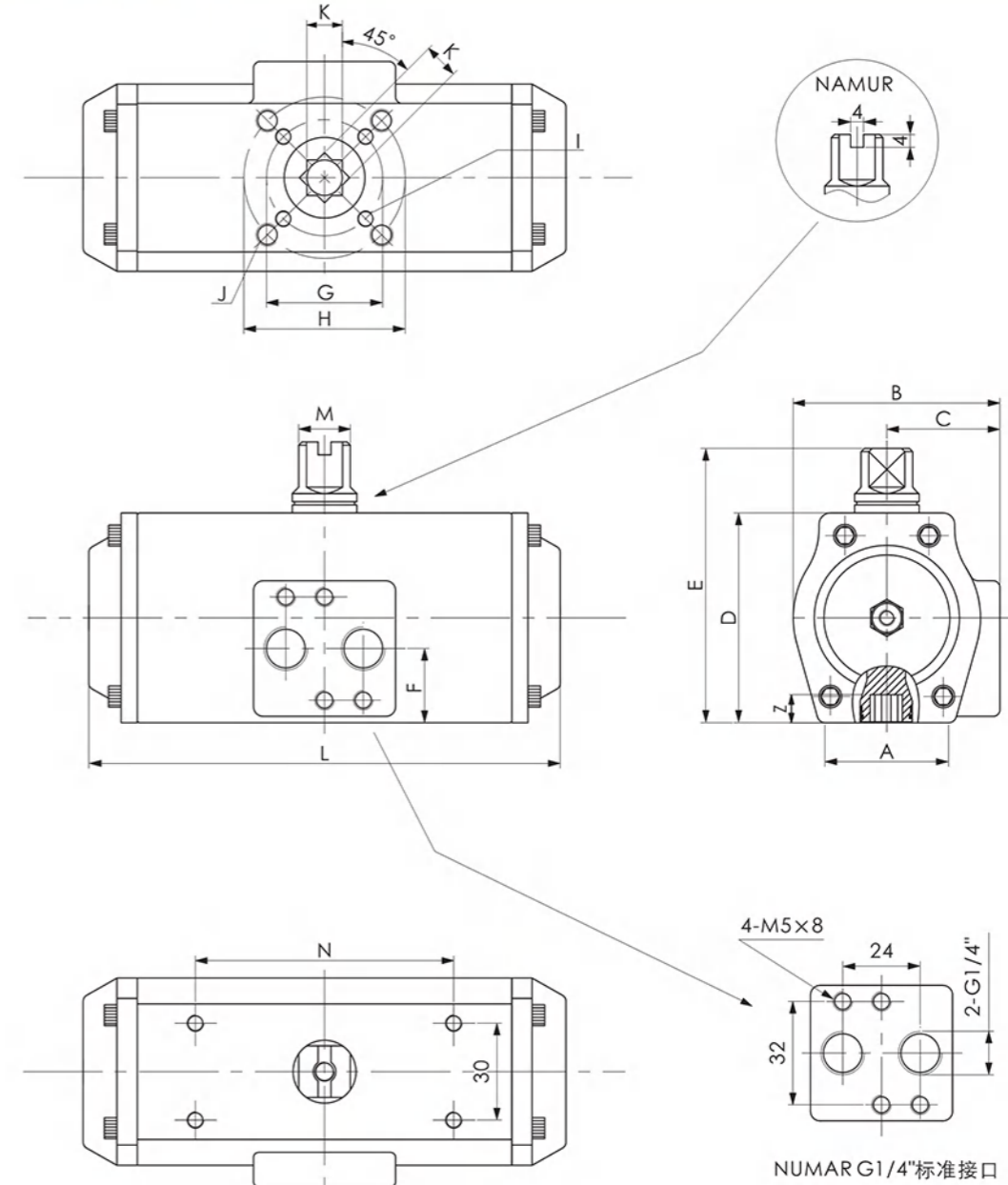

Unit: mm

Model 规格	A	B	C	D	E	F	G	H	I	J	K	L1	M	N	Z	Air Connection 接口螺纹
A-45	48	70	41	65	85	23	Φ36	Φ50	M5x8	M6x10	11	148	16	80	14	G1/4"
A-60	58	78	43	81	101	23		Φ50		M6x10	14	167	16	80	18	G1/4"
A-85	75	102	53.5	108	128	24	Φ50	Φ70	M6x10	M8x13	17	197	16	80	21	G1/4"
A-105	92	122	63.5	133	153	24		Φ70		M8x13	22	251	16	80	26	G1/4"
A-125	96	140	72	155	185	28	Φ70	Φ102	M8x13	M10x16	22	284	22	130	26	G1/4"
A-140	112	154	78	171.5	201.5	34	Φ102	Φ125	M10x16	M12x20	27	360	22	130	31	G1/4"
A-160	127	173	86	197	227	39	Φ102	Φ125	M10x16	M12x20	27	420	22	130	31	G1/4"
A-210	144	226	110	255	285	45		Φ140		M16x25	36	530	32	130	40	G1/4"

工作技术条件 Operating conditions

- | | |
|---|---|
| <p>1. 使用介质: 压缩空气、无腐蚀性气体和油;
 2. 压力范围: 双作用2~8巴 (Bar) , 单作用2~8巴 (Bar)
 3. 工作温度: 标准型 (使用丁腈橡胶O型圈) -20℃~+80℃
 低温型 (使用低温丁腈橡胶O型圈) -35℃~+80℃
 高温型 (使用氟橡胶O型圈) -15℃~+150℃
 4. 行程调整: 活塞在两端位置有±4° 的可调范围;
 5. 润 滑: 在正常工作条件下, 不需添加润滑剂;
 6. 安 装: 适合室内或室外安装;
 7. 最高使用压力: 输入气压不超过10巴。</p> | <p>1. Operating media
 Dry or lubricated air, the non-corrosive gases or oil.
 2. Air supply pressure
 Double acting: 2~8 Bar; Spring return: 2~8 Bar
 3. Operating temperature
 Standard: -20℃~+80℃
 Low temperature: -35℃~+80℃
 High temperature: -15℃~+150℃
 4. Travel adjustment
 Adjustment range of ±4° when the pistons at the sides.
 5. Lubrication
 Under normal operating condition, need not accrete lubricant
 6. Application
 Either indoor or outdoor
 7. Highest pressure
 The maximum input pressure is 10 Bar</p> |
|---|---|

耗气量计算 Air Consumption

A 系列执行器开向体积和关向体积 A Series Air volume opening & closing

Unit: L

型号 Model	开向体积 (升) Volume Opening	关向体积 (升) Volume Closing
A-45DA	0.08	0.11
A-63DA	0.20	0.23
A-85DA	0.41	0.55
A-105DA	0.94	1.18
A-125DA	1.47	1.85
A-140DA	2.43	3.20
A-160DA	3.65	5.03
A-210DA	7.4	9.7



耗气量取决于供气压力、开关行程、体积及动作次数,计算如下:

升/分=气缸体积 (开向体积+关向体积) × [(供气压力 (Kpa) +101.3) ÷ 101.3] × 次数/分钟

Air consumption rest with Air Supply. Air volume and Action cycle times, expressions:

L/Min=Air volume(Air volume Opening +Air volume closing) × [(Air Supply(Kpa)+101.3) ÷ 101.3] × Action cycle times (/min)

重量表 Weight Table

A 执行器系列 A Series

Unit: Kg

型号 Model	A-45	A-60	A-85	A-105	A-125	A-140	A-160	A-210
Weight(SR)	2.65	4.10	7.00	12.60	19.20	27.30	37.60	100.00
Weight(DA)	2.51	3.85	6.35	11.90	18.00	24.80	35.80	91.00



AC SERIES STAINLESS STEEL RACK & PINION ACTUATOR

Ac Series Stainless Steel Actuator

Ac系列不锈钢执行器

- * 304、304L、316、316L 不锈钢材质执行器，外表电解抛光，光洁美观，抗腐蚀性能强，适合于抗腐蚀要求极高的工程环境。
- * 双活塞齿轮齿条式设计，结构紧凑、安装位置对称、改变输出轴转向方便，使用寿命长、动作迅速。
- * 活塞齿条背面装有复合轴承及导向环，动作精确、摩擦系数小、使用寿命延长。
- * 组合式预负荷镀层弹簧，工作寿命长、抗腐蚀性能强。
- * 精密加工的齿轮和齿条，啮合间隙小、传动精度高，输出功率大。
- * 不锈钢紧固件，安全美观，抗腐蚀性强。
- * Ab 型——单向调节型
Ac 型——双位调节型
可满足不同客户的使用需求。
- * 采用国际规范尺寸：
输出轴槽、螺孔；
顶部安装孔尺寸符合 NAMUR 标准；
气源接口尺寸符合 NAMUR 标准；
底部安装孔尺寸符合 ISO 5211、
DIN 3337 标准，方便安装电磁阀限位开关等附件。

- * ASTM 304, 304L, 316, 316L stainless steel pneumatic actuator with electro-polish finish offer excellent resistance to most corrosive chemicals as well as industrial atmospheres.
- * Dual piston rack and pinion design for compact construction, symmetric mounting position, high-cycle life and fast operation, reverse rotation can be accomplished in the field by simply inverting the pistons.
- * Multiple bearings and guides on racks and pistons, low friction, high cycle life and prevent shaft blowout.
- * Modular preloaded spring cartridge design, with coated spring for simple versatile range, greater safety and corrosion resistance, longer cycle life.
- * Precise machined teeth on piston and pinion for accurate low backlash rack and pinion engagement, high transmission precision, maximum efficiency.
- * Stainless steel fasteners for long term corrosion resistance.
- * Ab model —— one-way adjustment
Ac model —— double adjustment
Can meet the needs of different customers.
- * Full conformance to the latest specifications: ISO 5211, DIN 3337 and Namur or product interchangeability and easy mounting of solenoids, limit switches and other accessories.

工作原理 Operating Principle

双作用执行器 Double Acting Actuators

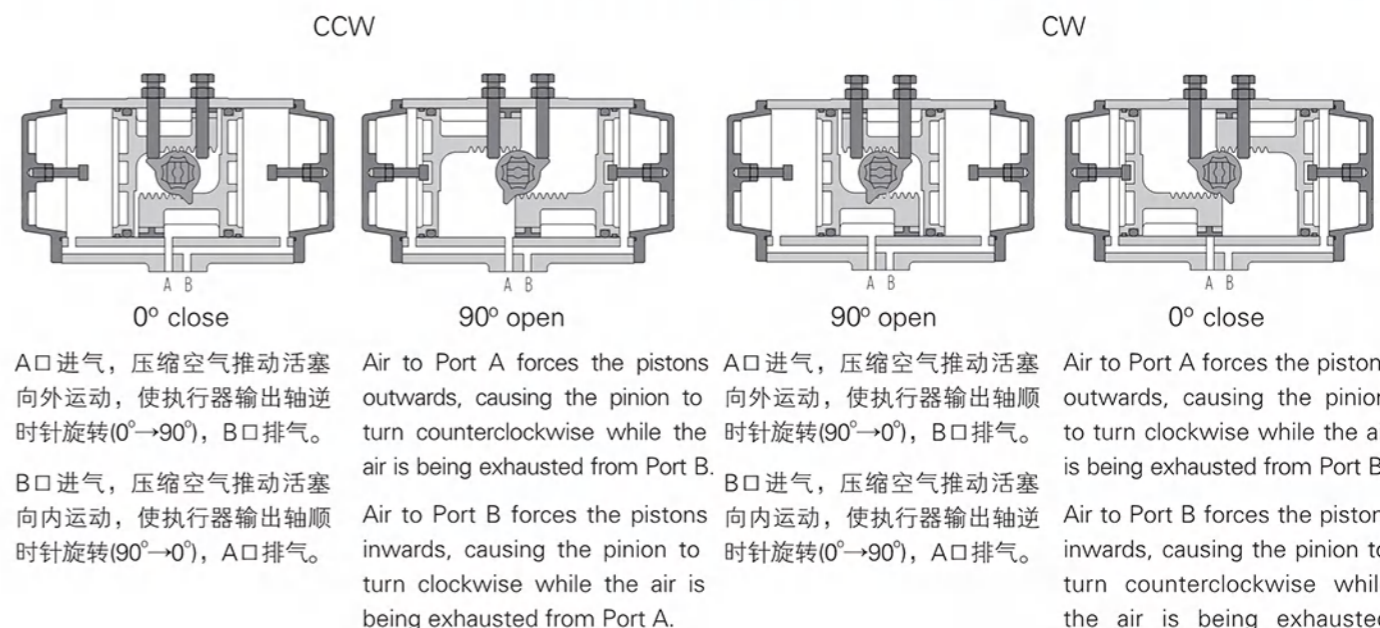

单作用执行器 Spring Return Actuators

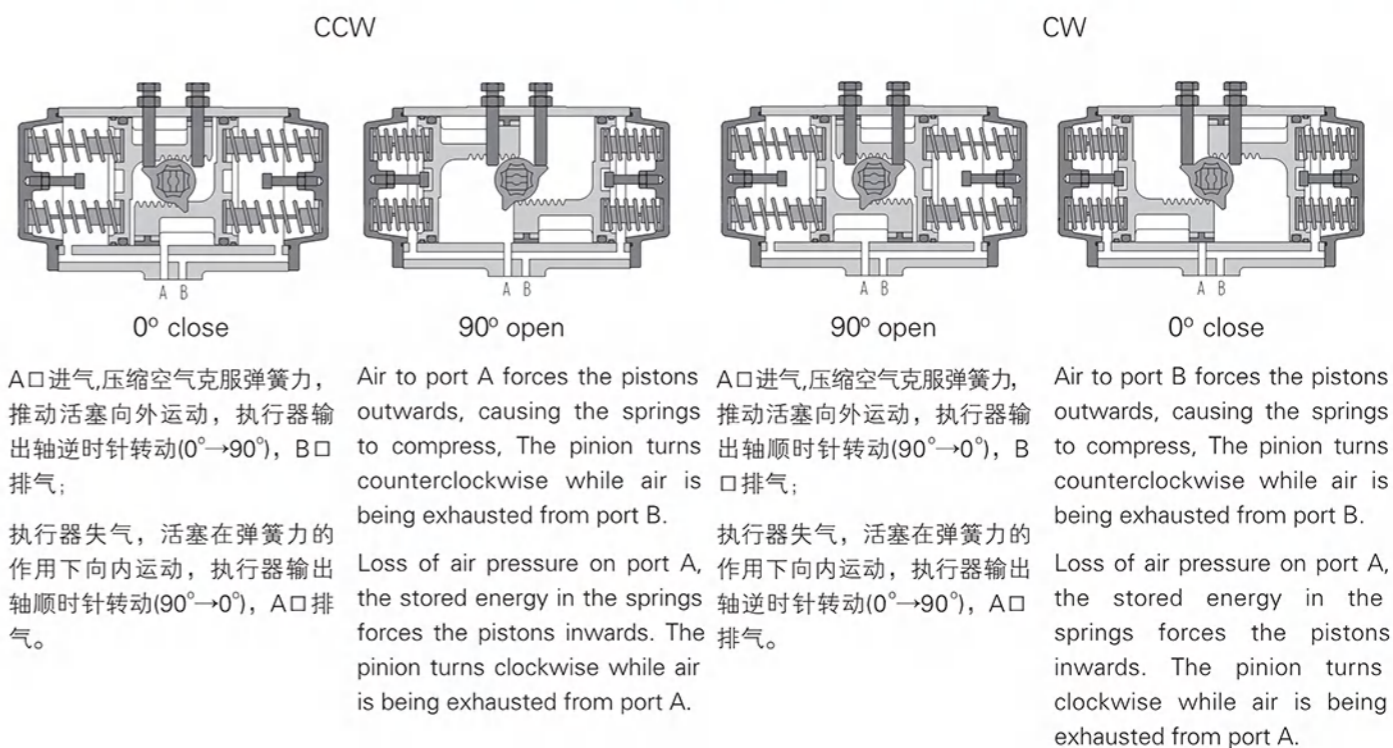

零件和材料 Parts and Materials

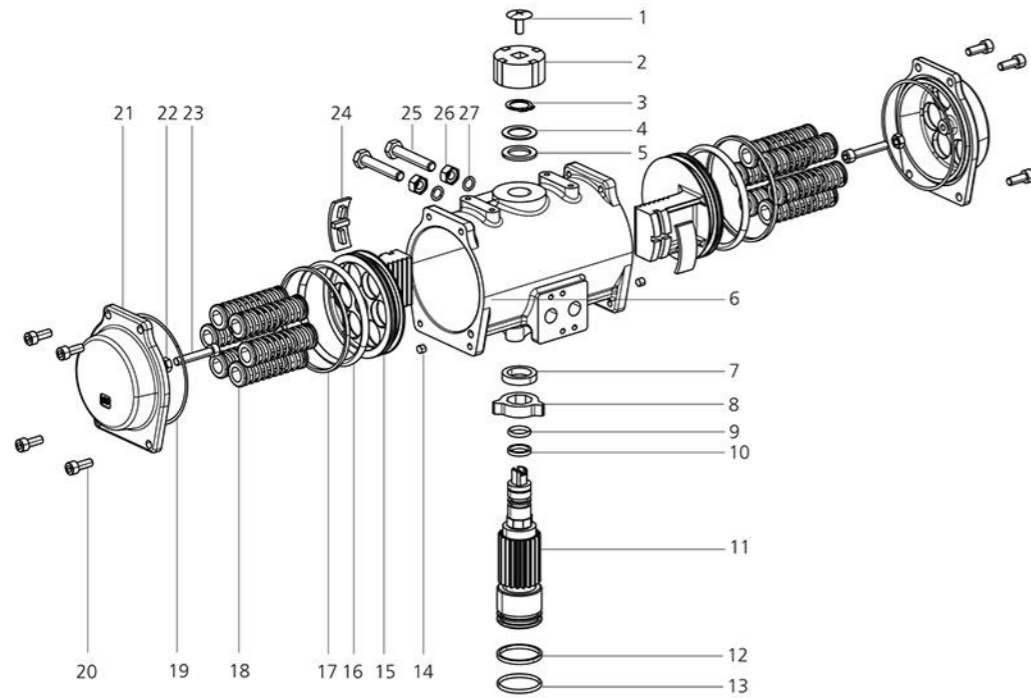

型号 Mdel : Ac45-160

序号 No.	名称 Description	数量 Qty.	材料 Standards Material
1	指示器螺钉 Indicator Screw	1	工程塑料 Polyoxymethylene
2	指示器 Indicator	1	工程塑料 Polyoxymethylene
3	弹性挡圈 Circlip	1	不锈钢 (304/316) Stainless Steel (304/316)
4	垫片 Thrust Washer	1	不锈钢 (304/316) Stainless Steel (304/316)
5	外垫片 Outside Washer	1	工程塑料 Polyoxymethylene
6	缸体 Body	1	不锈钢 (CF8/CF8M) Stainless Steel (CF8/CF8M)
7	内垫片 Inside Washer	1	工程塑料 Polyoxymethylene
8	凸轮 Cam	1	不锈钢 (304/316) Stainless Steel (304/316)
9	上轴O型圈 O-ring (Pinion Top)	1	氟橡胶/丁腈橡胶 Viton/NBR
10	上轴支撑圈 Bearing (Pinion Top)	1	工程塑料 Polyoxymethylene
11	轴 Pinion	1	不锈钢 (304/316) Stainless Steel (304/316)
12	下轴支撑圈 Bearing (Pinion Bottom)	1	工程塑料 Polyoxymethylene
13	下轴O型圈 O-ring (Pinion Bottom)	1	氟橡胶/丁腈橡胶 Viton/NBR
14	塞头 Plug	2	氟橡胶/丁腈橡胶 Viton/NBR
15	活塞 Piston	2	不锈钢 (CF8/CF8M) Stainless Steel (CF8/CF8M)
16	活塞支撑圈 Bearing (Piston)	2	工程塑料 Polyoxymethylene
17	活塞O型圈 O-ring (Piston)	2	氟橡胶/丁腈橡胶 Viton/NBR
18	弹簧 Spring	*	弹簧钢 Spring Steel
19	端盖O型圈 O-ring (End-Cap)	2	氟橡胶/丁腈橡胶 Viton/NBR
20	端盖紧固螺钉 End-Cap Screw	8	不锈钢 (304/316) Stainless Steel (304/316)
21	端盖 End-Cap	2	不锈钢 (CF8/CF8M) Stainless Steel (CF8/CF8M)
22	限位螺钉 Limit screw	2	不锈钢 (304) Stainless Steel (304)
23	限位螺母 Limit Nut	2	不锈钢 (304) Stainless Steel (304)
24	活塞导板 Guide (Piston)	2	工程塑料 Polyoxymethylene
25	调节螺栓 Adjust Screw	2	不锈钢 (304/316) Stainless Steel (304/316)
26	调节螺母 Nut (Adjust Screw)	2	不锈钢 (304/316) Stainless Steel (304/316)
27	调节螺母O型圈 O-ring (Adjust Nut)	2	氟橡胶/丁腈橡胶 Viton/NBR

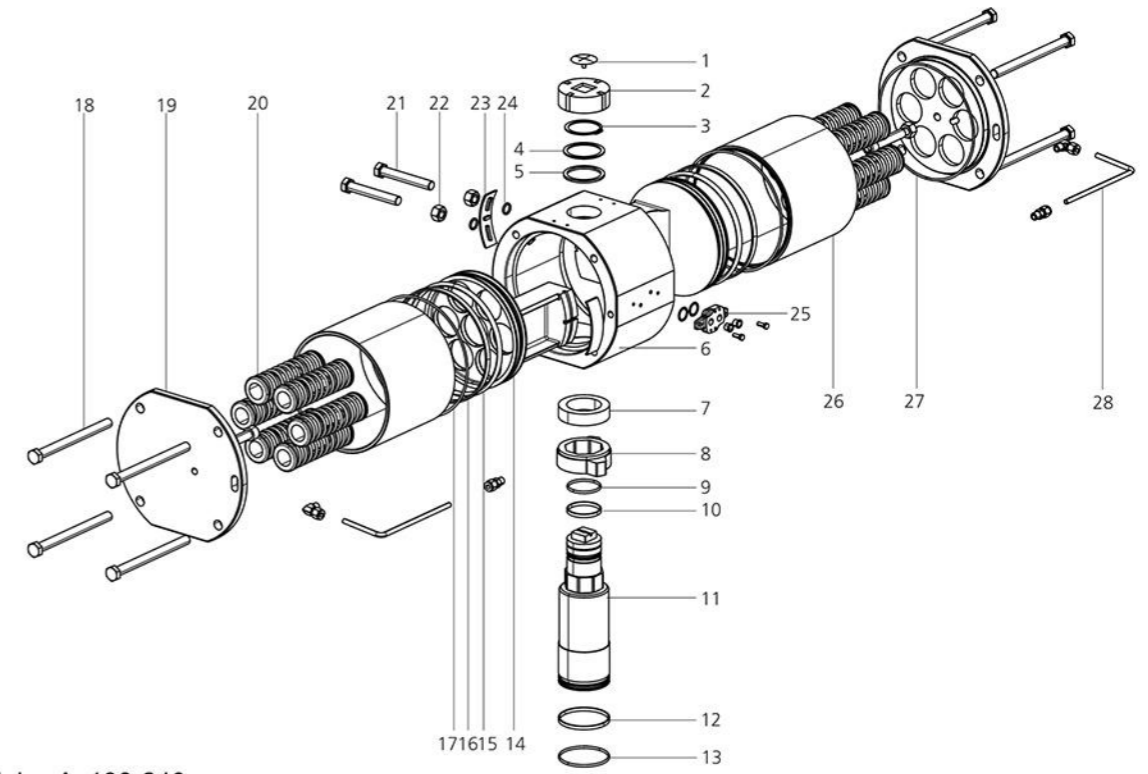

型号 Mdel : Ac190-240

序号 No.	名称 Description	数量 Qty.	材料 Standards Material
1	指示器螺钉 Indicator Screw	1	工程塑料 Polyoxymethylene
2	指示器 Indicator	1	工程塑料 Polyoxymethylene
3	弹性挡圈 Circlip	1	不锈钢 (304/316) Stainless Steel (304/316)
4	垫片 Thrust Washer	1	不锈钢 (304/316) Stainless Steel (304/316)
5	外垫片 Outside Washer	1	工程塑料 Polyoxymethylene
6	中间体 Middle Body	1	不锈钢 (F304/F316) Stainless Steel (F304/F316)
7	内垫片 Inside Washer	1	工程塑料 Polyoxymethylene
8	凸轮 Cam	1	不锈钢 (304/316) Stainless Steel (304/316)
9	上轴O型圈 O-ring (Pinion Top)	1	氟橡胶/丁腈橡胶 Viton/NBR
10	上轴支撑圈 Bearing (Pinion Top)	1	工程塑料 Polyoxymethylene
11	轴 Pinion	1	不锈钢 (304/316) Stainless Steel
12	下轴支撑圈 Bearing (Pinion Bottom)	1	工程塑料 Polyoxymethylene
13	下轴O型圈 O-ring (Pinion Bottom)	1	氟橡胶/丁腈橡胶 Viton/NBR
14	活塞 Piston	2	不锈钢 (CF8/CF8M) Stainless Steel (CF8/CF8M)
15	活塞O型圈 O-ring (Piston)	2	氟橡胶/丁腈橡胶 Viton/NBR
16	活塞支撑圈 Bearing (Piston)	2	工程塑料 Polyoxymethylene
17	侧体O型圈 O-ring (Lateral Body)	2	氟橡胶/丁腈橡胶 Viton/NBR
18	端盖紧固螺钉 End-Cap Screw	8	不锈钢 (304/316) Stainless Steel (304/316)
19	端盖 End-Cap	2	不锈钢 (304/316) Stainless Steel (304/316)
20	弹簧 Spring	*	弹簧钢 Spring Steel
21	调节螺栓 Adjust Screw	2	不锈钢 (304/316) Stainless Steel (304/316)
22	调节螺母 Adjust Nut	2	不锈钢 (304/316) Stainless Steel (304/316)
23	活塞导板 Guide (Piston)	2	工程塑料 Polyoxymethylene
24	调节螺母O型圈 O-ring (Adjust Nut)	2	氟橡胶/丁腈橡胶 Viton/NBR
25	NAMUR转接板组件 Adapter Plate Assembly	1	不锈钢 (304/316) Stainless Steel (304/316)
26	侧缸体 Lateral Body	2	不锈钢 (F304/F316) Stainless Steel (F304/F316)
27	端盖O型圈 O-ring (End-Cap)	2	氟橡胶/丁腈橡胶 Viton/NBR
28	管接组件 Pipe Connector Assembly	2	不锈钢 (304/316) Stainless Steel (304/316)

外形尺寸 Dimension

型号 Mdel : A45-160

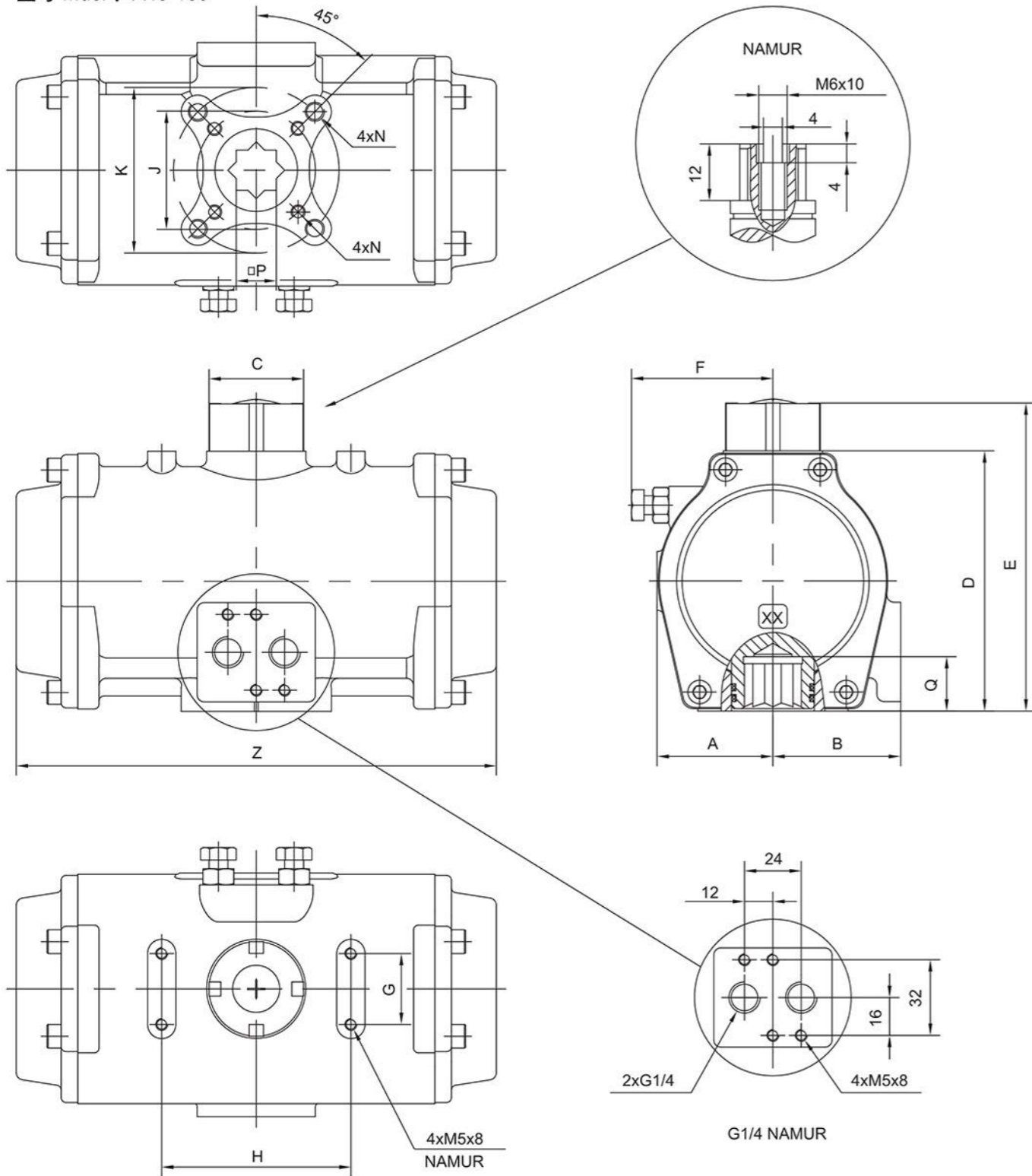

型号 Mdel : Ac190-240

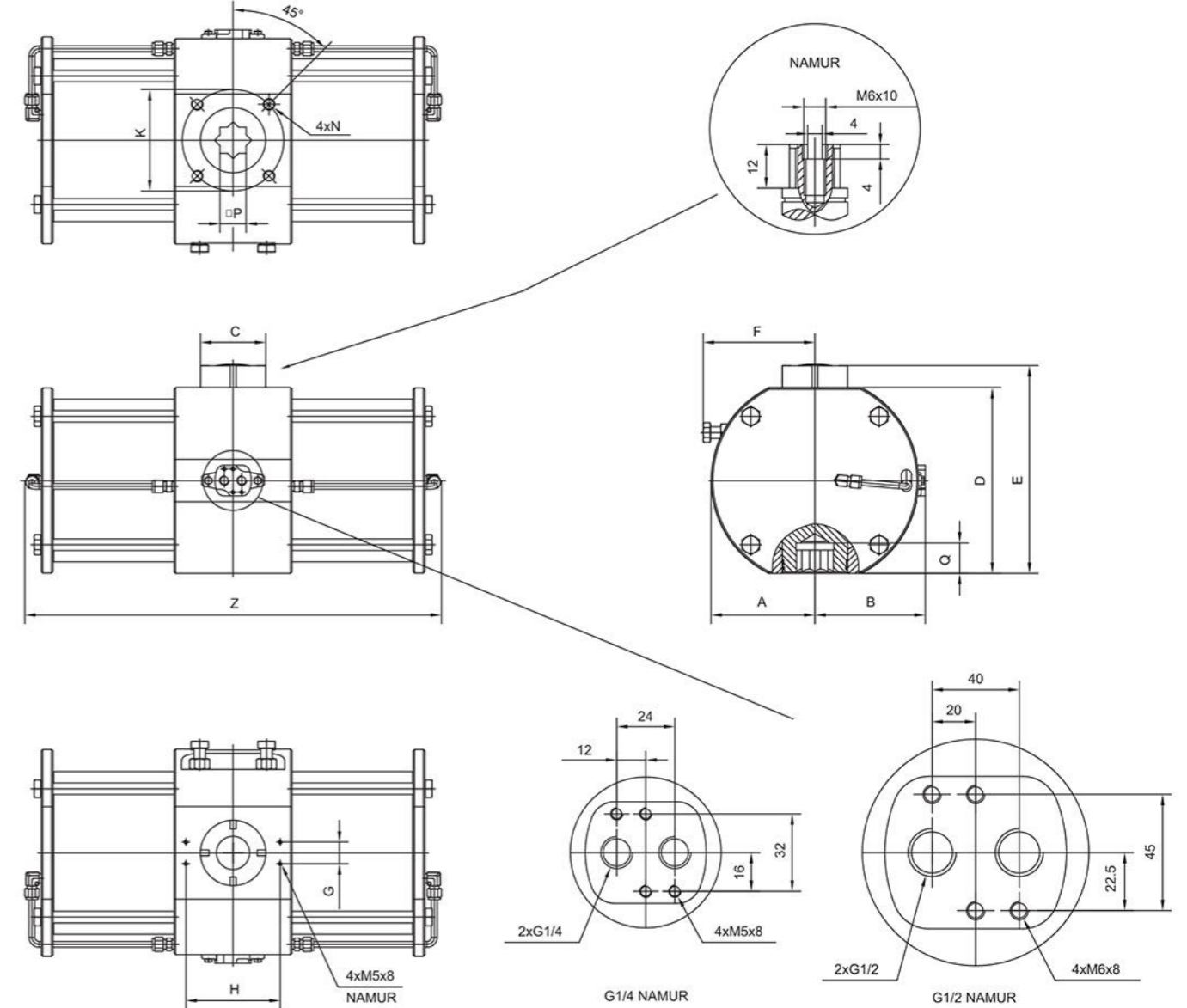

型号Model	A	B	C	D	E	F	G	H	J	K	M	N	P	Q	Z
Ac-45	28	40	Φ40	67	87	45	30	80	Φ36	Φ50	M5x8	M6x10	11	14	150
Ac-60	36	44	Φ40	83	103	52	30	80	Φ36	Φ50	M5x8	M6x10	14	17	165
Ac-85	49	54	Φ40	110	130	64	30	80	Φ50	Φ70	M6x10	M8x12	17	22	203
Ac-105	60	63	Φ40	135	155	75	30	80	Φ70	Φ102	M8x12	M10x16	22	26	256
Ac-125	70	69	Φ55	157	177	92	30	130	Φ70	Φ102	M8x12	M10x16	22	26	282
Ac-140	77	75	Φ55	174	204	105	30	130	Φ102	Φ125	M10x16	M12x20	27	32	365
Ac-160	88	82	Φ55	198	228	116	30	130	Φ102	Φ125	M10x16	M12x20	27	32	425
Ac-190	133	142	Φ80	234	264	147	30	130	-	Φ140	-	M16x24	36	40	575
Ac-210	143	152	Φ80	256	286	154	30	130	-	Φ140	-	M16x24	36	40	575
Ac-240	160	170	Φ80	288	318	174	30	130	-	Φ165	-	M20x25	46	50	650

双作用扭矩 Output Torque with Double Acting

双作用执行器输出力矩
Output Torque of Double Acting Actuators

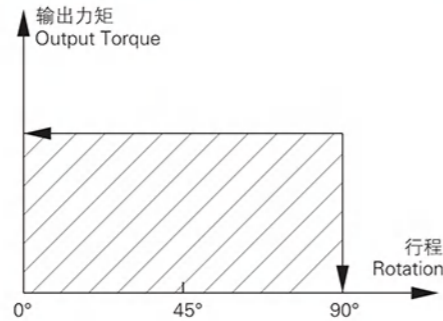

Ac系列气动执行器双作用输出扭矩表

Output Torque Table of AcSeries Pneumatic Actuators with Double Acting

Unit: Nm

规格 Model	气源压力 (巴) Air pressure(Bar)									
	2	2.5	3	4	4.5	5	5.5	6	7	8
Ac-45DA	6.0	7.6	9.1	12.1	13.6	15.1	16.6	18.1	21.1	24.2
Ac-60DA	14.2	17.8	21.3	28.4	32.0	35.5	39.1	42.6	49.7	56.8
Ac-85DA	30.8	38.5	46.2	61.6	69.4	77.1	84.8	92.5	107.9	123.3
Ac-105DA	65.8	82.2	98.7	131.6	148.0	164.4	180.9	197.3	230.2	263.1
Ac-125DA	103	128	154	205	231	256	282	308	359	410
Ac-140DA	175	219	263	351	395	439	482	526	614	702
Ac-160DA	267	334	401	535	601	668	735	802	935	1069
Ac-190DA	426	532	638	851	958	1064	1170	1277	1490	1702
Ac-210DA	526	658	789	1052	1184	1316	1447	1579	1842	2105
Ac-240DA	770	962	1154	1539	1731	1924	2116	2309	2693	3078

单作用扭矩 Output Torque with Spring Return

单作用执行器输出力矩
Output Torque of Spring Return Actuators

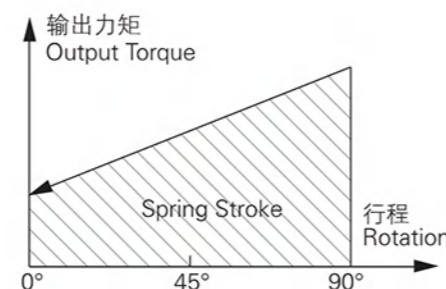
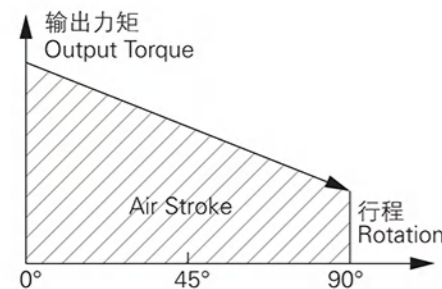

Ac系列单作用气动执行器输出扭矩表

Output Torque of Ac Series Pneumatic Actuator with Spring Return

unit: Nm

规格 (Model)	弹簧根数 Spring Qty.	气源压力(巴) Air pressure(Bar)																弹簧输出扭矩 Springs/output		
		2		2.5		3		4		5		6		7		8		90°	0°	
		0° Start	90° End	0° Start	90° End	0° Start	90° End	0° Start	90° End	0° Start	90° End	0° Start	90° End	0° Start	90° End	0° Start	90° End	Start	End	
Ac-45SR	5	3.0	1.2	4.6	2.8													4.6	2.9	
	6			3.9	1.8	5.4	3.3											5.5	3.5	
	7					4.8	2.3	7.8	5.3									6.5	4.1	
	8							7.2	4.3	10.2	7.3							7.4	4.6	
	9							6.6	3.4	9.6	6.4	12.6	9.4					8.3	5.2	
	10									9.0	5.4	12.0	8.4	15.0	11.4	18.1	14.5	9.2	5.8	
	11									8.4	4.4	11.4	7.4	14.4	10.4	17.5	13.5	10.1	6.4	
	12											10.8	6.5	13.8	9.5	16.9	12.6	11.1	7.0	
	Ac-60SR	5	7.0	3.2	10.6	6.8													10.4	6.8
		6			9.2	4.6	12.7	8.1											12.5	8.2
		7					11.2	5.9	18.3	13.0									14.6	9.6
		8							16.9	10.8	24.0	17.9							16.7	10.9
9								15.4	8.6	22.5	15.7	29.6	22.8					18.8	12.3	
10										21.1	13.5	28.2	20.6	35.3	27.7	42.4	34.8	20.9	13.7	
11										19.7	11.3	26.8	18.4	33.9	25.5	41.0	32.6	22.9	15.0	
12												25.3	16.2	32.4	23.3	39.5	30.4	25.0	16.4	
Ac-85SR		5	14.2	6.6	21.9	14.3													23.0	15.8
		6			18.5	9.4	26.2	17.1											27.6	19.0
		7					22.9	12.3	38.3	27.7									32.2	22.1
		8							35.0	22.8	50.5	38.3							36.8	25.3
	9							31.6	18.0	47.1	33.5	62.5	48.9					41.4	28.5	
	10									43.8	28.7	59.2	44.1	74.6	59.5	90.0	74.9	46.0	31.6	
	11									40.5	23.8	55.9	39.2	71.3	54.6	86.7	70.0	50.6	34.8	
	12											52.5	34.4	67.9	49.8	83.3	65.2	55.2	38.0	
	Ac-105SR	5	32.5	14.0	48.9	30.4													49.2	31.6
		6			42.2	20.0	58.7	36.5											59.1	38.0
		7					52.1	26.2	85.0	59.1									68.9	44.3
		8							78.3	48.7	111.1	81.5							78.7	50.6
9								71.7	38.4	104.5	71.2	137.4	104.1					88.6	56.9	
10										97.8	60.8	130.7	93.7	163.6	126.6	196.5	159.5	98.4	63.3	
11										91.1	50.4	124.0	83.3	156.9	116.2	189.8	149.1	108.3	69.6	
12										84.5	40.1	117.4	73.0	150.3	105.9	183.2	138.8	118.1	75.9	
Ac-125SR		5	47.9	20.5	72.9	45.5													78.4	52.4
		6			61.9	29.0	87.9	55.0											94.1	62.8
		7					76.8	38.5	127.8	89.5									109.7	73.3
		8							116.8	73.0	167.8	124.0							125.4	83.8
	9							105.8	56.5	156.8	107.5	208.8	159.5					141.1	94.2	
	10									145.8	91.0	197.8	143.0	248.8	194.0	299.8	245.0	156.8	104.7	
	11									134.8	74.5	186.8	126.5	237.8	177.5	288.8	228.5	172.4	115.2	
	12											175.7	110.0	226.7	161.0	277.7	212.0	188.1	125.7	
	Ac-140SR	5	84.7	39.3	128.7	83.3													129.0	85.8
		6			110.6	56.1	154.6	100.1											154.8	102.9
		7					136.6	73.0	224.6	161.0									180.5	120.1
		8							206.5	133.8	294.5	221.8							206.3	137.3
9								188.5	106.7	276.5	194.7	363.5	281.7					232.1	154.4	
10										258.4	167.5	345.4	254.5	433.4	342.5	521.4	430.5	257.9	171.6	
11										240.3	140.4	327.3	227.4	415.3	315.4	503.3	403.4	283.7	188.7	
12												309.3	200.2	397.3	288.2	485.3	376.2	309.5	205.9	
Ac-160R		5	120.0	47.7	187.0	114.7													208.3	139.7
		6			157.6	70.9	224.6	137.9											250	168
		7					195.2	94.0	329.2	228.0									292	196
		8							299.8	184.2	432.8	317.2							333	223
	9							270.4	140.3	403.4	273.3	537.4	407.3					375	251	
	10									374.0	229.5	508.0	363.5	641.0	496.5	775.0	630.5	417	279	
	11									344.6	185.6	478.6	319.6	611.6	452.6	745.6	586.6	458	307	
	12											449.2	275.7	582.2	408.7	716.2	542.7	500	335	

unit: Nm

规格(Model)	弹簧根数 (Spring Qty.)	气源压力(巴) Air pressure(Bar)																弹簧输出扭矩 Springs'output	
		2		2.5		3		4		5		6		7		8			
		0° Start	90° End	0° Start	90° End	0° Start	90° End	0° Start	90° End	0° Start	90° End	0° Start	90° End	0° Start	90° End	0° Start	90° End		
Ac-190SR	5	220	105	332	222													309	160
	6			292	161	398	267											371	200
	7					358	205	571	418									433	240
	8							531	356	744	569							495	280
	9							491	295	704	507	917	720					557	320
	10									664	446	877	658	1090	871	1302	1084	618	360
Ac-210SR	5	237	126	369	258													360	260
	6			311	178	442	309											432	313
	7					384	230	647	493									503	365
	8							589	413	853	677							575	417
	9							531	333	795	597	1058	860					647	469
	10									737	517	1000	780	1263	1043	1526	1306	709	521
Ac-240SR	5	341	190	552	409													554	410
	6			470	297	662	489											665	490
	7					580	379	964	764									775	575
	8							883	653	1267	1037							886	656
	9							800	542	1185	926	1569	1311					998	739
	10									1103	816	1488	1201	1872	1586	2257	1970	1108	821
	11								1021	705	1406	1090	1791	1471	2176	1859	1219	903	
	12										1323	979	1708	1363	2093	1748	1330	985	

工作技术条件 Operating Conditions

- | | |
|--|--|
| <p>1. 使用介质:
压缩空气、无腐蚀性气体;</p> <p>2. 压力范围:
双作用2~8巴(Bar), 单作用2~8巴(Bar)</p> <p>3. 工作温度:
标准型(使用丁腈橡胶O型圈)-20°C~+80°C
低温型(使用低温丁腈橡胶O型圈)-40°C~+80°C
高温型(使用氟橡胶O型圈)-15°C~+150°C</p> <p>4. 行程调整:
Ab型, 单向±5°可调;
Ac型, 开关位±5°可调</p> <p>5. 润滑:
在正常工作条件下, 不需添加润滑剂;</p> <p>6. 安装:
适合室内或室外安装;</p> <p>7. 最高使用压力:
输入气压不超过10巴(Bar)。</p> | <p>1. Operating media
Dry or lubricated air, the non-corrosive gases.</p> <p>2. Air supply pressure
Double acting: 2~8 Bar; Spring return: 2~8 Bar</p> <p>3. Operating temperature
Standard: -20°C~+80°C
Low temperature: -40°C~+80°C
High temperature: -15°C~+150°C</p> <p>4. Travel adjustment
Ab model, Have one-way adjustment range of ±5°;
Ac model, Have double adjustment range of ±5°.</p> <p>5. Lubrication
Under normal operating condition, need not accrete lubricant.</p> <p>6. Application
Either indoor or outdoor.</p> <p>7. Highest pressure
The maximum input pressure is 10 Bar.</p> |
|--|--|

耗气量 Air Consumption

型号 Model	开向体积 Volume Opening	关向体积 Volume Closing
Ac-45	0.08	0.11
Ac-60	0.2	0.23
Ac-85	0.41	0.55
Ac105	0.94	1.18
Ac-125	1.47	1.85
Ac-140	2.43	3.2
Ac-160	3.65	5.03
Ac-190	5.9	7.8
Ac-210	7.4	9.7
Ac-240	11	13.8

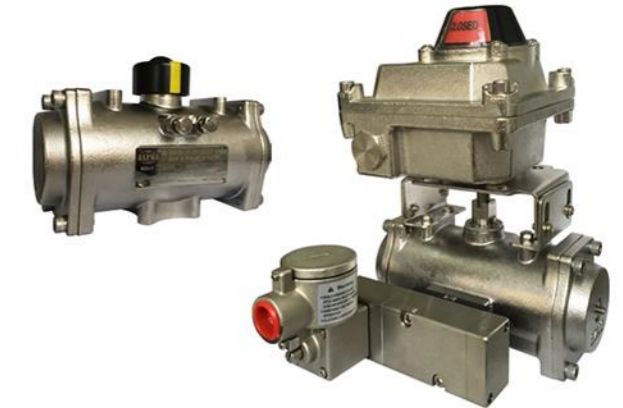

耗气量取决于供气压力、开关行程、体积及动作次数, 计算如下:
 升/分=气缸体积(开向体积+关向体积)×[(供气压力(Kpa)+101.3)÷101.3]×次数/分钟
 Air consumption rest with Air Supply. Air volume and Action cycle times, expressions:
 L/Min=Air volume(Air volume Opening +Air volume closing)×[(Air Supply(Kpa)+101.3)÷101.3]×Action cycle times (/min)

重量表 Weight Table

型号 Model	Ac-45	Ac-60	Ac-85	Ac-105	Ac-125	Ac-140	Ac-160	Ac-190	Ac-210	Ac-240
重量 Weight (DA)	2.0	3.0	6.4	9.7	14.1	20.9	29.9	81.0	92.6	125.7
重量 Weight (SR)	2.1	3.1	6.8	10.5	15.5	23.2	33.6	87.7	102.2	139.5

动作时间 Operation Time

型号 Model	Ac-45	Ac-60	Ac-85	Ac-105	Ac-125	Ac-140	Ac-160	Ac-190	Ac-210	Ac-240
0°-90°(DA)	0.5	0.7	0.9	1.5	2	2.5	3.5	4	4.5	6
90°-0°(DA)	0.5	0.7	0.8	1.5	2	2.5	3	5	5	6
0°-90°(SR)	1	1.5	2	2.5	3	3.5	4	5	6	8
90°-0°(SR)	0.5	0.8	1	1	1.5	1.5	2	4	5	5

执行器动作时间与电磁阀、减压阀、气管等配件的Cv值, 气源压力, 负载等因素有关。
 我们可以根据客户要求定制气孔来改变执行器的动作时间。
 The operating time of the actuators depends on the CV values of the solenoid valves, regulator valves, pipes. It depends on the air supply, operating load and so on.
 We can custom the size of the holes to meet the require of the operating time of the actuators.



全不锈钢气缸系列

All Stainless Steel Cylinder Series

通过 ISO9001 国际质量体系认证



全不锈钢标准气缸 (拉杆式) All Stainless Steel Standard Cylinders (Rod Type) BSC 系列 (φ32-φ200)



标准规格

内径 (mm)	32	40	50	63	80	100
动作方式	复动型					
工作介质	空气 (经 40 μm 滤网过滤)					
固定式	BSC 系列	基本型 FA型 FB型 CA型 CB型 LB型 TC型 Y型				
型式	BSCD, BSCJ 系列	基本型 FA型 LB型 TC型 Y型 I型				
使用压力范围	0.1~1.0MPa(14~145psi)					
保证耐压力	1.5MPa(215psi)					
工作温度 °C	-20~80					
使用速度范围 mm/s	30~800					
行程公差范围	0~250 ^{+1.0}	251~1000 ^{+1.0}	1001~1500 ^{+1.0}			
缓冲型式	可调缓冲					
缓冲行程 mm	21		28		29	
* 接管口径	PT1/8	PT1/4	PT3/8		PT1/2	

* 接管牙型有 NPT、G 牙可供选择。

符号



产品特性

- 1、本企业标准气缸;
- 2、活塞密封采用异型双向密封结构, 尺寸紧凑, 有储油功能;
- 3、为拉杆式气缸, 前后盖与不锈钢缸体用支柱连接, 可靠性好;
- 4、采用不锈钢材质, 具有耐腐蚀和防酸碱性能;
- 5、气缸缓冲调节平稳;
- 6、多种规格的气缸及不锈钢安装附件可供客户选择使用;
- 7、可按客户选择耐高温耐腐蚀密封材料, 使气缸在 150°C 高温条件下正常工作。

外形尺寸图 (毫米)

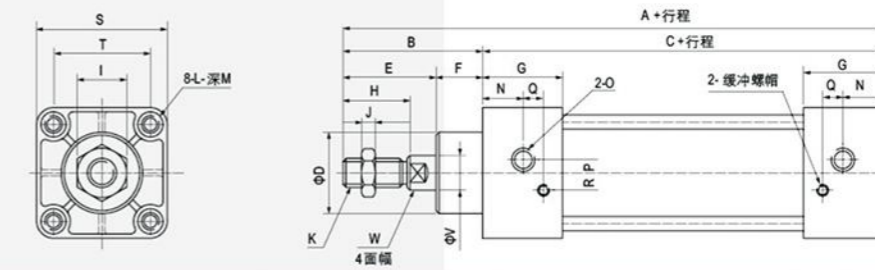

缸径 / 符号	A	B	C	D	E	F	G	H	I	J	K	L	M	N	O	P	Q	R	S	T	V	W
32	140	47	93	28	32	15	27.5	22	17	6	M10×1.25	M6×1	9.5	13.7	G1/8"	3.5	7.5	7	45	33	12	10
40	142	49	93	32	34	15	27.5	24	17	7	M12×1.25	M6×1	9.5	13.5	G1/4"	6	8.2	9	60	37	16	14
50	150	57	93	38	42	15	27.5	32	23	8	M16×1.5	M6×1	9.5	13.5	G1/4"	8.5	8.2	9	62	47	20	17
63	153	57	96	38	42	15	27.5	32	23	8	M16×1.5	M8×1.25	9.5	13.5	G3/8"	7	8.2	8.5	75	56	20	17
80	182	75	108	47	54	21	33	40	26	10	M20×1.5	M10×1.5	11.5	16.5	G3/8"	10	9.5	14	84	70	25	22
100	189	75	114	47	54	21	33	40	26	10	M20×1.5	M10×1.5	11.5	16.5	G1/2"	11	9.5	14	112	84	25	22
125	246	101	145	57	69	32	40	54	39	11	M27×2	M12×1.75	15	20	G1/2"	-	-	-	140	110	32	29
160	300	135	165	65	100	33	45	72	52	14	M36×2	M16×2	15	25	G1/2"	-	-	-	180	140	40	36
200	339	150	189	70	100	50	50	72	52	14	M36×2	M16×2	30	25	G3/4"	-	-	-	220	175	50	46

行程

系列名称	内径 (mm)	标准行程	最大行程	容许行程
BSC	32	25 50 75 80 100 125 150 160 175 200	1000	2000
	40	250 300 350 400 450 500	1200	2000
	50	25 50 75 80 100 125 150 160 175 200	1200	2000
	63	250 300 350 400 450 500 600 700 800	1500	2000
	80	900 1000	1500	2000
100		1500	2000	

注: 在最大行程范围内, 若行程 ≥1600mm, 作非标处理, 其它特殊行程请与本公司联系。

全不锈钢标准气缸 All Stainless Steel Standard Cylinders BMBB 系列 (φ32-φ125)



标准规格

内径 (mm)	32	40	50	63	80	100	125
工作方式	复动型						
工作介质	空气 (经 40μm 滤网过滤)						
固定形式	BMBB	基本型 FA FB CA CB CR LB TC TCM1 TCM2					
形式	BMBBD, BMBBJ 系列	基本型 FA LB TC TCM1 TCM2					
使用压力范围	0.1~1.0Mpa (14~145psi)						
保证耐压力	1.5MPa (215psi)						
工作温度℃	-20~80						
使用速度范围 mm/s	30~800					30~500	
行程公差范围	0~250 ^{±0.05}		251~1000 ^{±0.14}		1001~1500 ^{±0.18}		
缓冲型式	可调缓冲						
缓冲行程 mm	24			32		37.5 40	
*接管口径	PT1/8"	PT1/4"	PT3/8"		PT1/2"		

*接管牙型有 NPT、G 牙可供选择。

产品特性

- 1、本企业标准气缸；
- 2、活塞密封采用异型双向密封结构，尺寸紧凑，有储油功能；
- 3、为拉杆式气缸，前后盖与不锈钢缸体用支柱连接，可靠性好；
- 4、采用不锈钢材质，具有高耐腐蚀和防酸碱性；
- 5、气缸缓冲调节平稳；
- 6、多种规格的气缸及不锈钢安装附件可供客户选择使用；
- 7、可按客户选择耐高温耐腐蚀密封材料，使气缸在 150℃ 高温条件下正常工作。

行程

内径 (mm)	标准行程															最大行程	容许行程
32	25	50	75	80	100	125	150	160	175	200	300	350	400	450	500	1000	1800
40																1200	1800
50																1200	1800
63																1500	1800
80																1500	1800
100																1500	1800
125																1500	1800

注：其它特殊行程请与本公司联系

符号



外形尺寸图 (毫米)

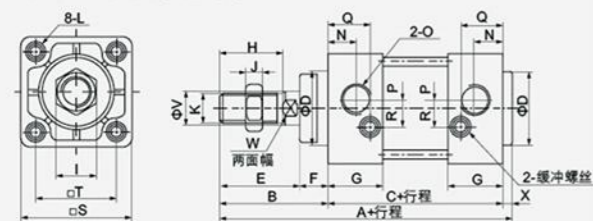

缸径 / 符号	A	B	C	D	E	F	G	H	I	J	K	L	N	O	P	Q	R	S	T	V	W	X
32	135	47	84	30	34	13	27	22	17	6	M10 × 1.25	M6	13	PT1/8"	4	20.5	6.5	48	32.5	12	10	4
40	139	51	84	35	38	13	27	30	19	8	M14 × 1.5	M6	14	PT1/4"	4	20.5	9	52	38	16	14	4
50	156	58	94	40	44	14	31.5	35	27	11	M18 × 1.5	M8	15.5	PT1/4"	5	23	10.5	65	46.5	20	18	4
63	156	58	94	45	44	14	31.5	35	27	11	M18 × 1.5	M8	16.5	PT3/8"	9	23	12	75	56.5	20	18	4
80	190	72	114	45	52	20	38	40	32	13	M22 × 1.5	M16	19	PT3/8"	11.5	26.5	14	95	72	25	22	4
100	190	72	114	55	52	20	38	40	36	13	M26 × 1.5	M10	19	PT1/2"	17	26.5	15	114	89	30	26	4
125	223	97	120	60	70	27	38	54	41	13.5	M22 × 2	M12	19	PT1/2"	17	29	15	137	110	32	27	6

不锈钢附件 Stainless steel accessory



不锈钢配件 Stainless steel fittings



* 耐腐蚀耐高温的氟橡胶密封圈